

External Roll-a-Finish® tools

XBB series

For burnishing the outside diameter of cylindrical parts, such as shafts rotating in bushings or bearings. Provides an ideal surface for grease and oil seals.

Available from stock for nominal diameters from 1,5 to 20,0 mm (.059 to .787 inches). Micro XBB tools and XBB tools larger than 20,0mm are available upon request.



XBB 1,5-20,0

Offered in *two styles*:

- **Micro XBB tools**, with a very small body diameter and short overall length, are designed for Swiss auto-style machines. The tools cover a range of nominal diameters from 1,00 to 9,00mm (.039 to .354 inch).
- **Regular XBB tools** are available for nominal sizes from 1,5 to 65,0mm (.059 to 2.559 inch).

All XBB tools are bottoming-style and require machine feeding. The tools are adjustable in increments of .002mm (.0001 inch).



XBB 21,0-40,0

Standard tool specifications

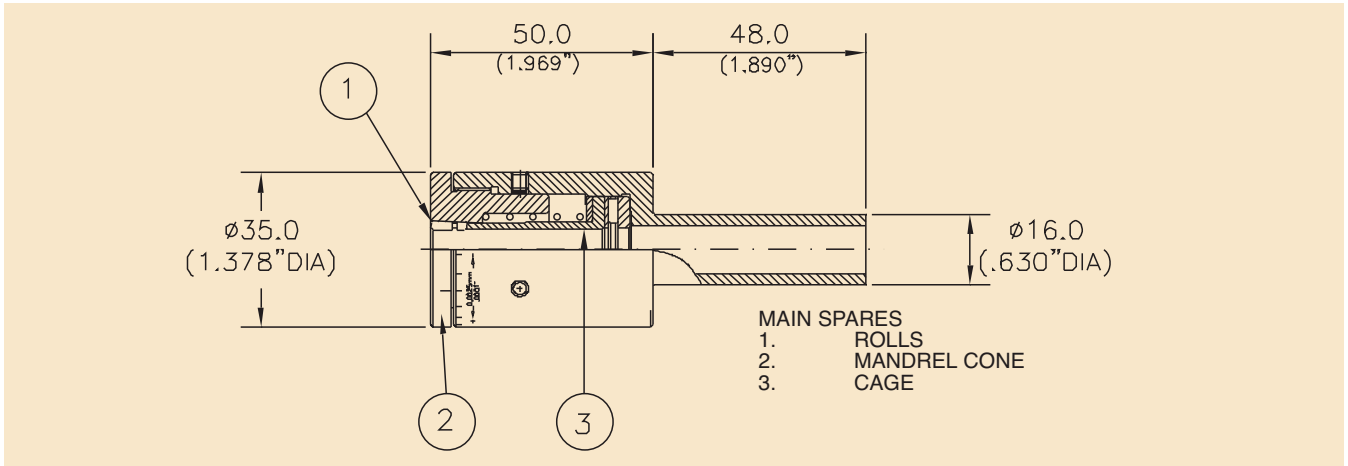

MICRO XBB SERIES ROLL-A-FINISH® TOOLS

1,00 to 9,00mm (.039" to .354")

DIAMETER RANGE				TOOL NUMBER
MIN		MAX		BOTTOMING (No Helix)
mm	Inches	mm	Inches	
0,75	.030	1,025	.040	MICRO 1,00
1,00	.039	1,275	.050	MICRO 1,25
1,25	.049	1,525	.060	MICRO 1,50
1,50	.059	1,775	.070	MICRO 1,75
1,75	.069	2,025	.080	MICRO 2,00
2,00	.079	2,275	.090	MICRO 2,25
2,25	.089	2,525	.099	MICRO 2,50
2,50	.098	2,775	.109	MICRO 2,75
2,75	.108	3,025	.119	MICRO 3,00
3,00	.118	3,275	.129	MICRO 3,25
3,25	.128	3,525	.139	MICRO 3,50
3,50	.138	3,775	.149	MICRO 3,75
3,75	.148	4,025	.158	MICRO 4,00
4,00	.158	4,275	.168	MICRO 4,25
4,25	.167	4,525	.178	MICRO 4,50
4,50	.177	4,775	.188	MICRO 4,75
4,75	.187	5,025	.198	MICRO 5,00
5,00	.197	5,275	.208	MICRO 5,25
5,25	.207	5,525	.218	MICRO 5,50
5,50	.217	5,775	.227	MICRO 5,75
5,75	.226	6,025	.237	MICRO 6,00
6,00	.236	6,275	.247	MICRO 6,25
6,25	.246	6,525	.257	MICRO 6,50
6,50	.256	6,775	.267	MICRO 6,75
6,75	.266	7,025	.277	MICRO 7,00
7,00	.276	7,275	.286	MICRO 7,25
7,25	.285	7,525	.296	MICRO 7,50
7,50	.295	7,775	.306	MICRO 7,75
7,75	.305	8,025	.316	MICRO 8,00
8,00	.315	8,275	.326	MICRO 8,25
8,25	.325	8,525	.336	MICRO 8,50
8,50	.335	8,775	.345	MICRO 8,75
8,75	.344	9,025	.355	MICRO 9,00

Standard tool specifications

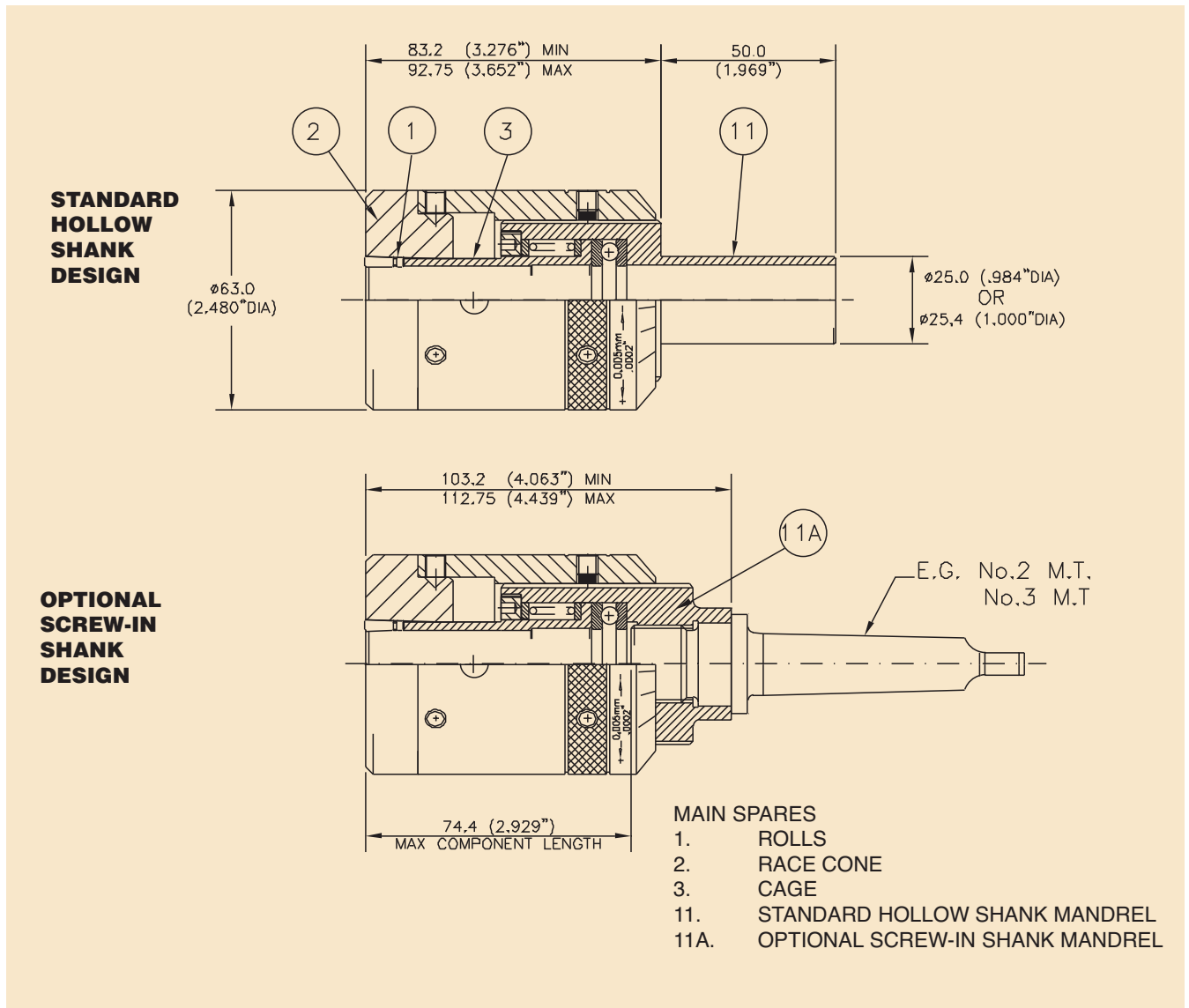

XBB SERIES ROLL-A-FINISH® TOOLS

1,5 to 20,0mm (.059" to .787")

SEE NEXT PAGE FOR CHART

Standard tool specifications

XBB SERIES ROLL-A-FINISH® TOOLS

1,5 to 20,0mm (.059" to .787")

DIAMETER RANGE				TOOL NUMBER
MIN		MAX		BOTTOMING (No Helix)
mm	Inches	mm	Inches	
1,00	.039	1,60	.063	XBB 1,5
1,50	.059	2,10	.083	XBB 2,0
2,00	.078	2,60	.102	XBB 2,5
2,50	.098	3,10	.122	XBB 3,0
3,00	.118	3,60	.142	XBB 3,5
3,50	.138	4,10	.161	XBB 4,0
4,00	.157	4,60	.181	XBB 4,5
4,50	.177	5,10	.201	XBB 5,0
5,00	.197	5,60	.220	XBB 5,5
5,50	.217	6,10	.240	XBB 6,0
6,00	.236	6,60	.260	XBB 6,5
6,50	.256	7,10	.280	XBB 7,0
7,00	.276	7,60	.299	XBB 7,5
7,50	.295	8,10	.319	XBB 8,0
8,00	.315	8,60	.339	XBB 8,5
8,50	.335	9,10	.358	XBB 9,0
9,00	.354	9,60	.378	XBB 9,5
9,50	.374	10,10	.398	XBB 10,0
10,00	.394	10,60	.417	XBB 10,5
10,50	.413	11,10	.437	XBB 11,0
11,00	.433	11,60	.457	XBB 11,5
11,50	.453	12,10	.476	XBB 12,0
12,00	.472	12,60	.496	XBB 12,5
12,50	.492	13,10	.516	XBB 13,0
13,00	.512	13,60	.535	XBB 13,5
13,50	.531	14,10	.555	XBB 14,0
14,00	.551	14,60	.575	XBB 14,5
14,50	.571	15,10	.594	XBB 15,0
15,00	.591	15,60	.614	XBB 15,5
15,50	.610	16,10	.634	XBB 16,0
16,00	.630	16,60	.654	XBB 16,5
16,50	.650	17,10	.673	XBB 17,0
17,00	.669	17,60	.693	XBB 17,5
17,50	.689	18,10	.713	XBB 18,0
18,00	.709	18,60	.732	XBB 18,5
18,50	.728	19,10	.752	XBB 19,0
19,00	.748	19,60	.772	XBB 19,5
19,50	.768	20,10	.791	XBB 20,0

Optional Self-Feeding 1/2° Helix Style Tools are Available from XBB 6,5 onwards

Standard tool specifications

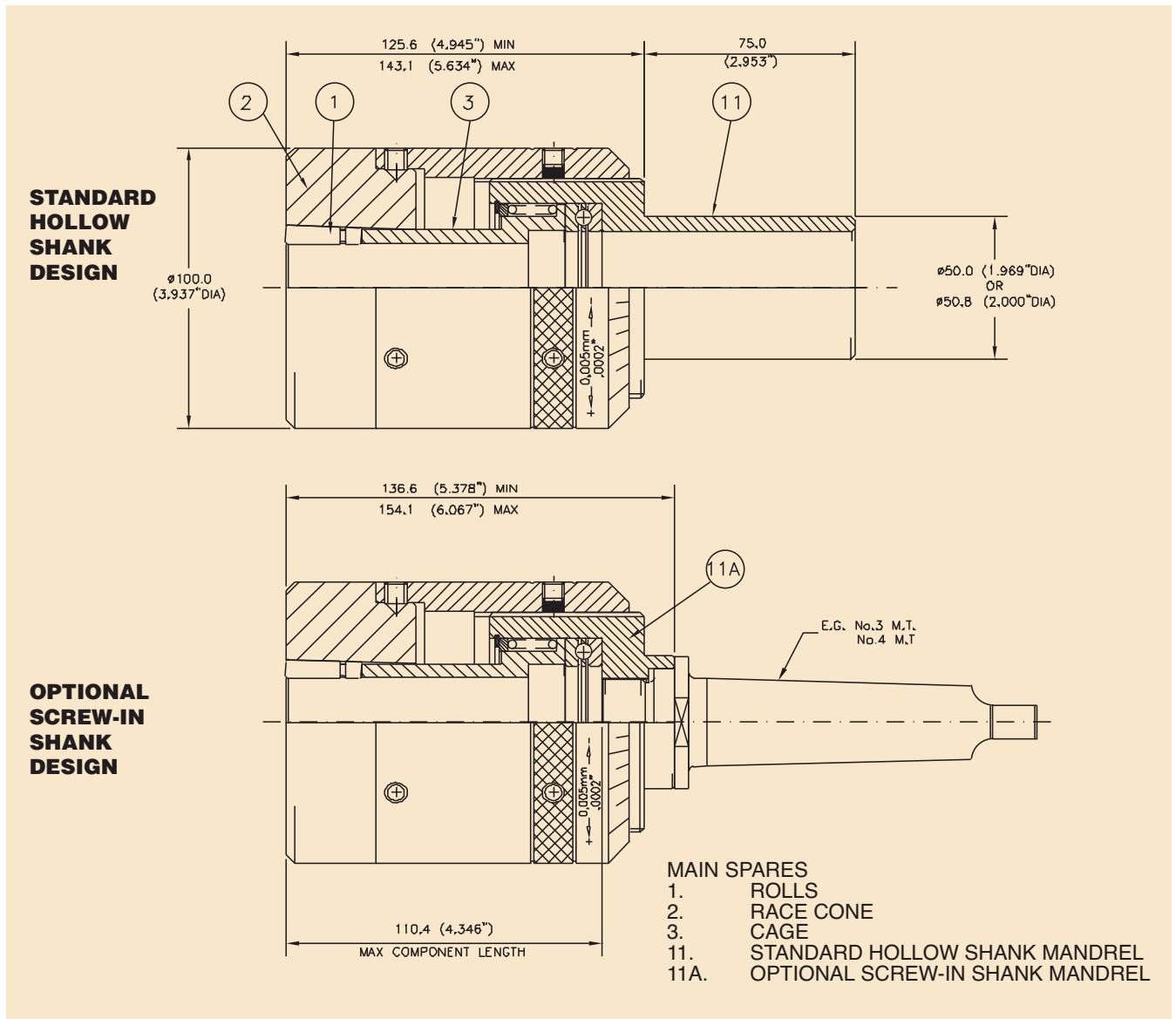

XBB SERIES ROLL-A-FINISH® TOOLS

21,0 to 40,0mm (.827" to 1.575")

SEE NEXT PAGE FOR CHART

XBB SERIES ROLL-A-FINISH® TOOLS

21,0 to 40,0mm (.827" to 1.575")

DIAMETER RANGE				TOOL NUMBER
MIN		MAX		BOTTOMING (No Helix)
mm	Inches	mm	Inches	
20,00	.787	21,10	.831	XBB 21
21,00	.827	22,10	.870	XBB 22
22,00	.866	23,10	.909	XBB 23
23,00	.906	24,10	.949	XBB 24
24,00	.945	25,10	.988	XBB 25
25,00	.984	26,10	1.028	XBB 26
26,00	1.024	27,10	1.067	XBB 27
27,00	1.063	28,10	1.106	XBB 28
28,00	1.102	29,10	1.146	XBB 29
29,00	1.142	30,10	1.185	XBB 30
30,00	1.181	31,10	1.224	XBB 31
31,00	1.220	32,10	1.264	XBB 32
32,00	1.260	33,10	1.303	XBB 33
33,00	1.299	34,10	1.343	XBB 34
34,00	1.339	35,10	1.382	XBB 35
35,00	1.378	36,10	1.421	XBB 36
36,00	1.417	37,10	1.461	XBB 37
37,00	1.457	38,10	1.500	XBB 38
38,00	1.496	39,10	1.539	XBB 39
39,00	1.535	40,10	1.579	XBB 40

Optional Self-Feeding 1 1/2° Helix Style Tools are Available for all Sizes in this Range

Standard tool specifications

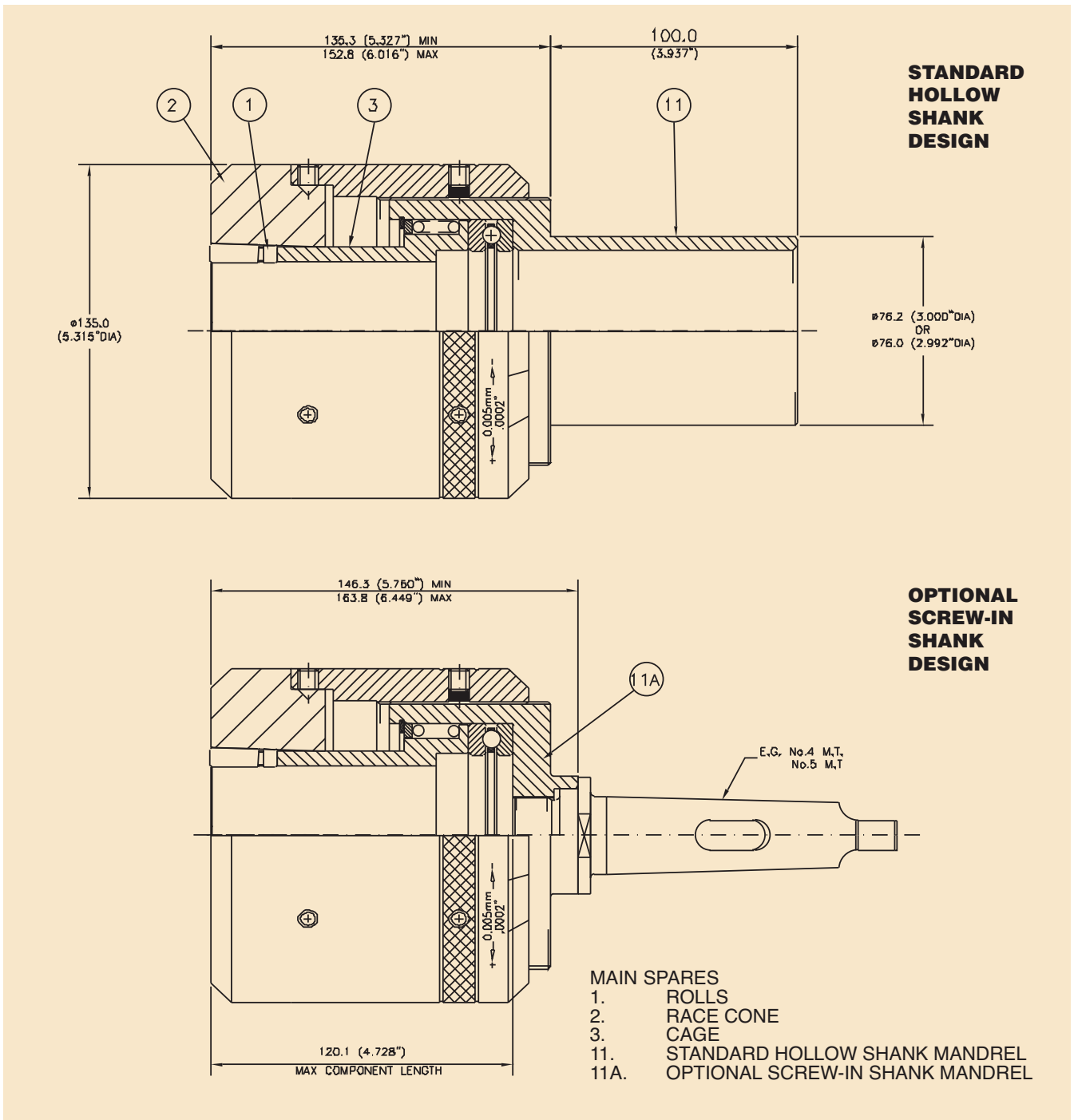

XBB SERIES ROLL-A-FINISH® TOOLS

41,0 to 65,0mm (1.614" to 2.559")

SEE NEXT PAGE FOR CHART

XBB SERIES ROLL-A-FINISH® TOOLS

41,0 to 65,0mm (1.614" to 2.559")

DIAMETER RANGE				TOOL NUMBER
MIN		MAX		BOTTOMING (No Helix)
mm	Inches	mm	Inches	
40,00	1.575	41,10	1.618	XBB 41
41,00	1.614	42,10	1.657	XBB 42
42,00	1.654	43,10	1.697	XBB 43
43,00	1.693	44,10	1.736	XBB 44
44,00	1.732	45,10	1.776	XBB 45
45,00	1.772	46,10	1.815	XBB 46
46,00	1.811	47,10	1.854	XBB 47
47,00	1.850	48,10	1.894	XBB 48
48,00	1.890	49,10	1.933	XBB 49
49,00	1.929	50,10	1.972	XBB 50
50,00	1.969	51,10	2.012	XBB 51
51,00	2.008	52,10	2.051	XBB 52
52,00	2.047	53,10	2.091	XBB 53
53,00	2.087	54,10	2.130	XBB 54
54,00	2.126	55,10	2.169	XBB 55
55,00	2.165	56,10	2.209	XBB 56
56,00	2.205	57,10	2.248	XBB 57
57,00	2.244	58,10	2.287	XBB 58
58,00	2.283	59,10	2.327	XBB 59
59,00	2.323	60,10	2.366	XBB 60
60,00	2.362	61,10	2.406	XBB 61
61,00	2.402	62,10	2.445	XBB 62
62,00	2.441	63,10	2.484	XBB 63
63,00	2.480	64,10	2.524	XBB 64
64,00	2.520	65,10	2.563	XBB 65

Optional Self-Feeding 1/2° Helix Style Tools are Available for all Sizes in this Range

ROLLS

EXTERNAL ROLLER BURNISHING ROLL CHART		
TOOL NUMBER		QTY / TOOL
(FROM - TO)	BOTTOMING	
MICRO XBB 1,00-5,50	B250	3
MICRO XBB 6,00-9,00	B250	5
XBB 1,50 - 5,50	B312	3
XBB 6,0 - 20	B438	5
XBB 21 - 40	B875	7
XBB 41 - 65	B1125	9